

# PRESIDENT

## MC-8000 DSC

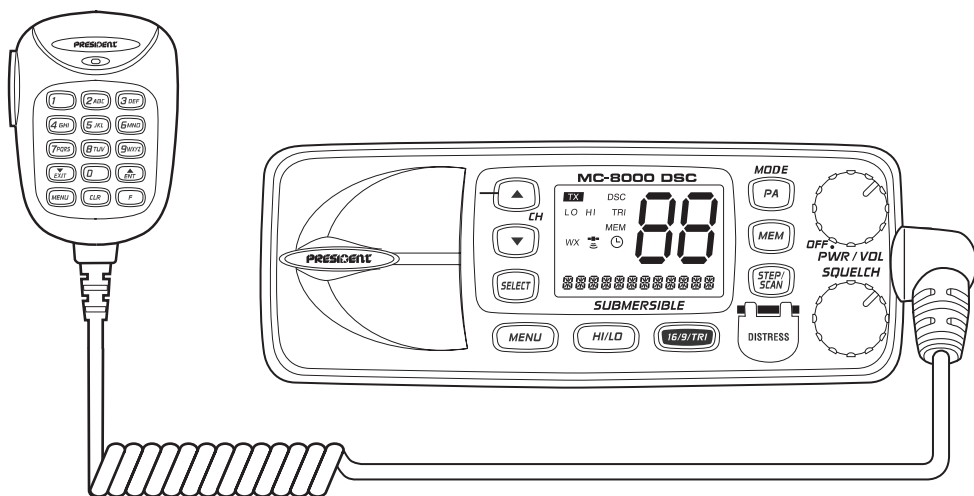

Owner's Manual

---

# Contents

---

Included with your MC-8000 DSC .....	4
Controls and Indicators .....	5
Fornt Panel/Microphone .....	5
Rear Panel Connectors .....	6
ACC Connectors .....	6
LCD Display .....	7
Flow Chart for Menu Operation .....	8
Installation .....	9
Choosing a Location .....	9
Engine Noise Suppression .....	9
Installing the MC-8000 DSC .....	9
Operation .....	10
Power On/Off .....	10
Last Channel Memory .....	10
Squelch .....	11
Channel 16/Channel 9 Communications .....	11
Triple Watch .....	12
Manual Tuning .....	12
Mem (Entering channel numbers into Memory Scan) .....	12
Triple Watch Scan .....	12
Normal Scan .....	13
Transmitting .....	13
Setting TX Output .....	13
Distress .....	13
Switching the Inland waterway Mode / Seagoing Mode .....	14
Menu Operation .....	15
Digital Selective Calling (DSC) .....	15
Individual .....	15
Group .....	16
All Ships .....	17
Position Request .....	17
Position Send .....	18
Standby .....	19
Call Wait .....	19
Setup .....	21
Alarm Clock .....	21
Local Time Adjust .....	22

Daylight Savings On/Off .....	23
Directory .....	23
Auto Channel Switch .....	25
Position Reply .....	26
CH Tag .....	27
Group MMSI .....	28
User MMSI .....	28
Atis ID .....	29
System .....	30
Contrast .....	30
Lamp Adjust .....	30
Key Beep .....	31
NMEA Technical Setup .....	31
VHF FM Marine Radio Telephone Channel and Functions (International Channels) .....	32
Specification .....	33
Troubleshooting .....	34
Warranty .....	34
Certificate of Conformity .....	35

---

## Included with your MC-8000 DSC

---

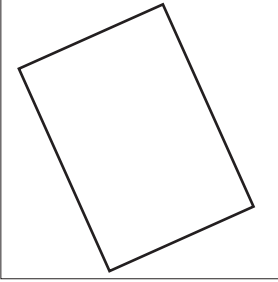

MC-8000 DSC  
Owner's Manual

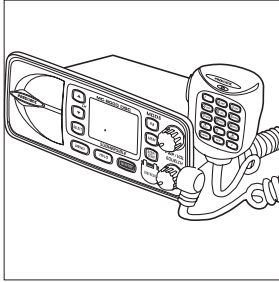

MC-8000 DSC Radio

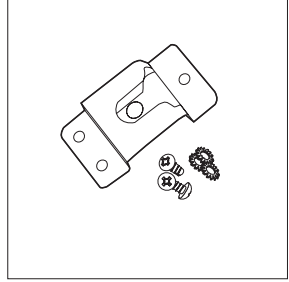

Microphone Hanger  
and Screws

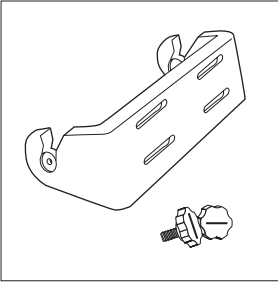

Mounting Bracket  
and Knobs

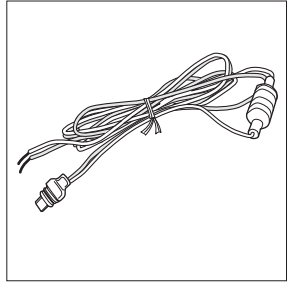

DC Cord

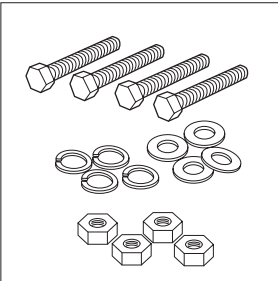

Mounting Hardware

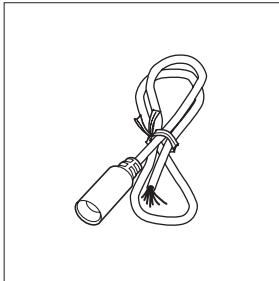

Accessory Cable

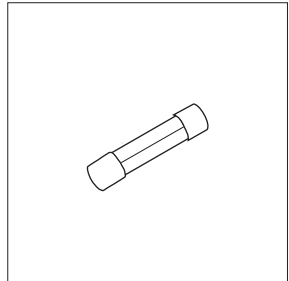

Spare Fuse  
250V 6A

---

## Controls and Indicators

---

### Front Panel/Microphone

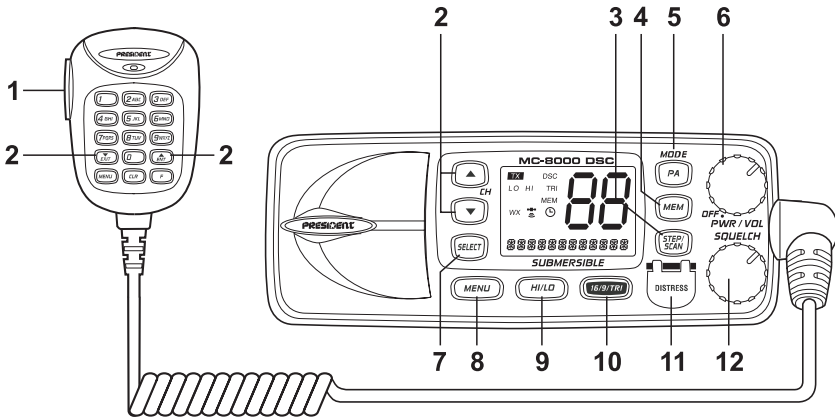

1. **PTT Switch** - Press to transmit and release to receive.
2. **CHANNEL ▲ / ▼** - These keys are used to change the channel number up/down. These buttons are also used to move the cursor in Menu mode.
3. **STEP/SCAN** - Press this key to activate the step operation. Every time this key is pushed, the radio will step to the next channel that has placed into Memory. Pressing and holding this key for 2 seconds will activate the channel scan feature.
4. **MEM** - Pressing this key will place the currently selected channel into Memory.
5. **PA / MODE** - Press this key to enable the PA (Public Address) feature / Inland Waterway Mode
6. **PWR/VOL (On/Off/Volume)** - Turns the unit On or Off and adjusts the speaker volume.
7. **SELECT** - In the Menu mode this is used to select the menu options.
8. **MENU** - Press this key to enter the Menu mode.
9. **HI/LO** - Press this key to change the transmit power to either High or Low.
10. **16/9/TRI** - Press this key instantly change to Channel 16, Channel 9 or current channel. Pressing and holding this key for 2 seconds will activate the triple Watch Feature.
11. **DISTRESS** - Press this key to send a signal of distress in case of emergency.
12. **SQUELCH** - Rotate this knob eliminate background noise when a signal is not being received.

## Rear Panel Connectors

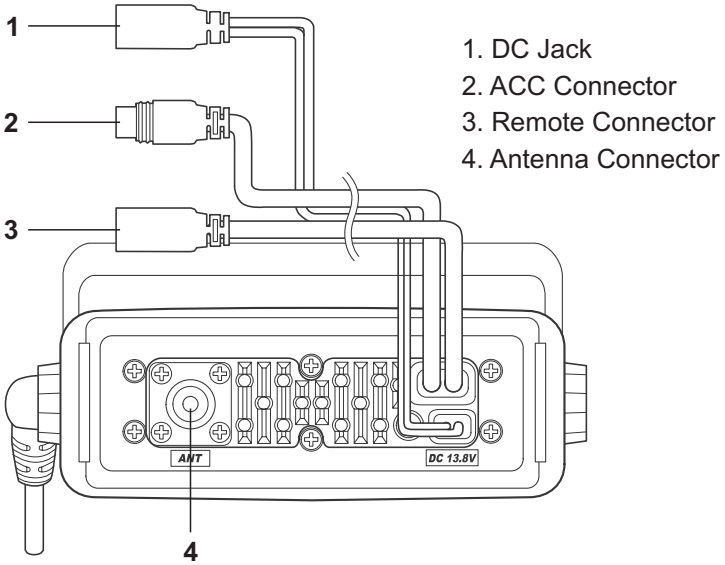

## ACC Connectors

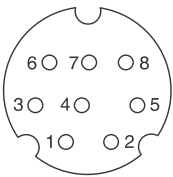

Pin number	Color	Signal
1	ORG	External Speaker (+)
2	RED	DC +13.8 V
3	BRN	PA (+)
4	GRN	GPS DATA IN
5	—	—
6	BAR	PA (-) (GND)
7	BLK	External Speaker (-) (GND)
8	BLU	NC

To MC-8000 DSC

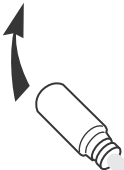

- Orange : External Speaker (+)
- Black : External Speaker (-) (GND)
- Green : GPS DATA IN
- Red : DC +13.8 V
- Bare Wire: PA (-) (GND)
- Brown : PA (+)
- Blue : NC

**Note:** DC13.8V and GND are for GPS ANT.

## LCD Display

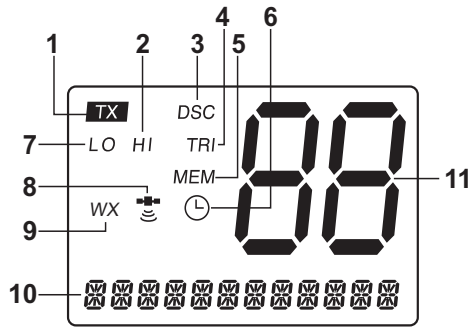

1. **TX** (Transmit) - Indicates transmitting.
2. **HI** (High) - Indicates transmit output is 25 Watts.
3. **DSC** - Indicates the radio is in the DSC mode.
4. **TRI** (Triple Watch) - Indicates Triple Watch Mode is in effect.
5. **MEM** (Memory) - Indicates Memory Scan Mode status for each channel selected.
6. 🕒 (**Alarm Icon**) - It appears when the alarm clock is set.
7. **LO** (Low) - Indicates transmit output is 1 Watt.
8. 📶 (**GPS Icon**) - It appears while GPS module is receiving the data.
9. **WX** - It appears when Inland Waterway Mode is selected.
10. **CH TAG** - This area is used for Channel Tag, Menu, DSC, GPS. These messages will continually scroll from right to the left.
11. **Channel Display** - Indicates Channel Number in use.

# Flow Chart for Menu Operation

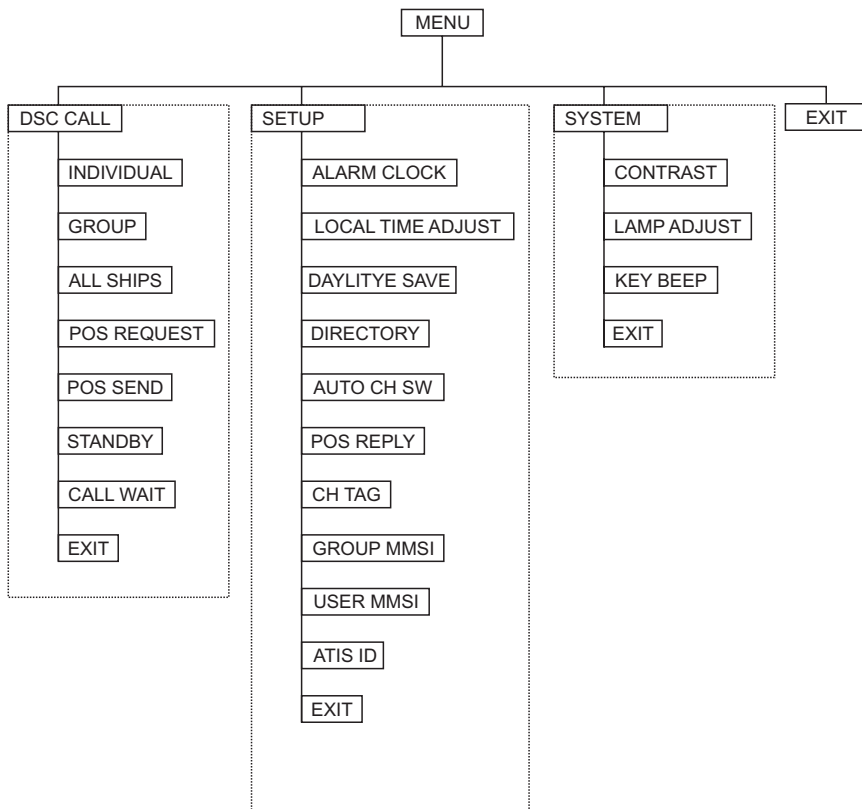

**Notes:** "POS SEND", "LOCAL TIME ADJUST", "DAYLITE SAVE", and "ALARM CLOCK" are not displayed in Menu when GPS module is not connected.

When the radio is in one of the following modes: **Channel 16/9** mode, **Scan** Mode, or **Triple Watch** mode, and the user presses the **Menu** key, all of these modes are cancelled.

The menu mode will be cancelled if the radio receives a DSC call or **EXIT** is selected.

---

## Installation

---

**Caution:** The **MC-8000 DSC** will only operate with a nominal 12 volt negative ground battery system.

It is important to carefully determine the most suitable location for your radio on your vessel. Electrical, mechanical, and environmental considerations must all be taken into account. You should select the optimum relationship among these considerations.

Keep in mind the flexibility designed into the **MC-8000 DSC** so that you can most conveniently use it. Features which should be considered are:

1. The universal mounting bracket may be installed on either the top or bottom of a shelf, on a bulkhead, or for overhead mounting.
2. The REMOTE speaker wires can be used with an auxiliary speaker.
3. All connections are “plug-in” type for easy removal of the radio.

### Choosing a Location

Some important factors to consider in selecting the location for your **MC-8000 DSC**.

1. Select a location that is free from spray and splash.
2. Keep the battery leads as short as possible. Direct connection to the battery is most desirable.
3. Keep the antenna lead as short as possible. Long antenna leads can cause substantial loss of performance for both receiving and transmitting.
4. Locate your antenna as high as possible and clear from metal objects. The reliable range of coverage is a direct function of the antenna height.
5. Select a location that allows free air flow around the heat sink on the rear of the radio.
6. Select a location well away from the ship's compass. Auxiliary speakers also should be located away from the compass.

### Engine Noise Suppression

Interference from the noise generated by the electrical systems of engines is sometimes a problem with radios. The **MC-8000 DSC** has been designed to be essentially impervious to ignition noise and alternator noise. However, in some installations it may be necessary to take measures to further reduce the effect of noise interference. All DC battery wires, antenna lead, and accessory cables should be routed away from the engine and engine compartment, and from power cabling carrying high currents.

### Installing the MC-8000 DSC

After you have carefully considered the various factors affecting your choice of location, position the radio (with the bracket, microphone, power cord, antenna and any auxiliary cables installed) into the selected location to assure there is no interference with the surrounding items. Mark the location of the mounting bracket. Remove the bracket from the radio and use it as a template to mark the holes to be drilled for the mounting hardware. Drill the holes and mount the bracket with hardware compatible with the material of the mounting surface.

**Note:** This HEXAGON HEAD BOLT is only for mounting the bracket with hardware. Do not use it for installing the radio in the mounting bracket.

Connect the red wire of the supplied power cord to the positive (+) battery supply. Connect the black wire of the power cord to the negative (-) battery supply. The power cord is equipped with a fuse to protect the radio. Use only a six (6) ampere fast blow fuse for replacement. Connect the power cord to the keyed connector on the power "pigtail".

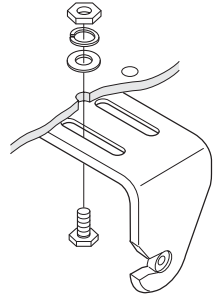

Connect the antenna and all other auxiliary cables and accessories.

Install the radio in the mounting bracket and connect all cables and accessories to the appropriate jacks and connectors.

**Note:** Do not use any other mounting knobs than the ones enclosed. Do not insert the knobs without attaching the bracket.

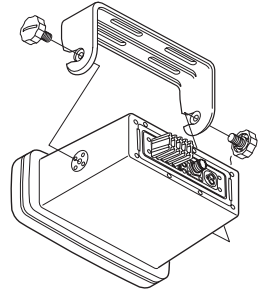

---

## Operation

---

### Power On/Off

Turn the unit On by rotating the **PWR/VOL** control clockwise.

Adjust the volume to a comfortable level.

When you turn the unit On, you will hear a beep, and the greeting message below appears on the LCD for 3 seconds.

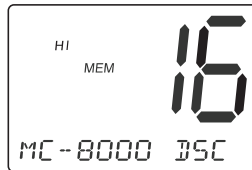
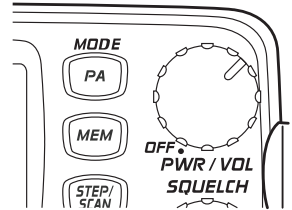

**Note:** When you turn On the radio for the first time after purchase, the channel 16 will appear on the LCD.

### Last Channel Memory

The **MC-8000 DSC** memorizes the last channel selected before you turn Off the radio. For example, if you turn Off the radio on CH 12, it will be on that channel when turned back On.

**Note:** In order for the last channel to be memorized, you must have the radio on that channel for 3 seconds.

# Squelch

Turn **SQUELCH** fully clockwise. This raises the “Squelch Gate” so high that only very strong signals can get through.

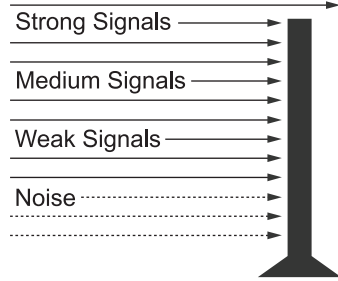
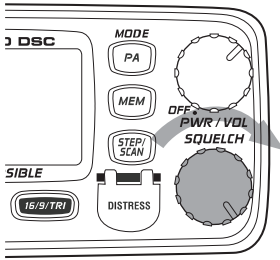

Turn **SQUELCH** fully counterclockwise until you hear a hiss. This lowers the “Squelch Gate” so that everything gets through - noise, weak signals, and strong signals.

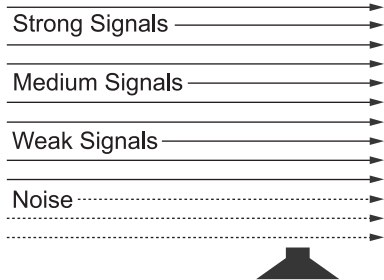
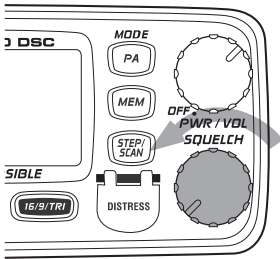

Turn **SQUELCH** back clockwise until the hiss stops. Now the “Squelch Gate” allows only strong signals through.

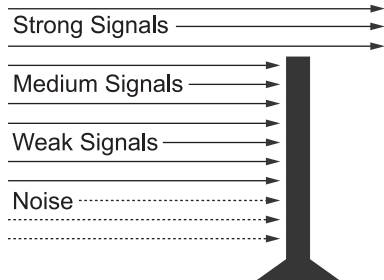
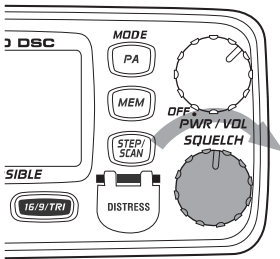

## Channel 16/Channel 9 Communications

To access Channel 16 or Channel 9 communications, press **16/9/TRI**. You can access 16 CH instantly while tuned to another channel. Press **16/9/TRI** again for Channel 9 Calling commu-

nications. Press **16/9/TRI** a third time to return to the channel selected prior to accessing Channel 16/Channel 9 communications.

The display will indicate the selected channel.

To cancel Channel 16/Channel 9 communications:

- Press **16/9/TRI** until the previous channel setting appears.  
- - or - -
- Press **CH ▲**, **CH ▼** or **STEP/SCAN**.

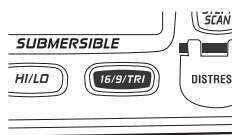

## Triple Watch

Triple Watch monitors Channel 16, Channel 9, and the current Marine Channel.

To activate Triple Watch, press and hold **16/9/TRI** for 2 seconds. **TRI** appears on the LCD, indicating Triple Watch mode is in effect. If a signal is received on either Channel 16 or Channel 9, the radio remains on that channel until the signal ends.

Press and hold **16/9/TRI** for 2 seconds to cancel the Triple Watch mode.

**Note:** While in Triple Watch mode, you can change the currently selected channel using **CH ▲** or **CH ▼**.

A momentary press of the **16/9/TRI** button interrupts Triple Watch mode and remains on channel 16, or on channel 9 if you press **16/9/TRI** once more. To return to the Triple Watch mode, simply press the button again.

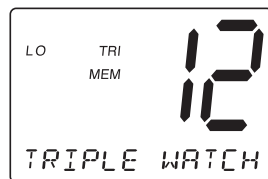

## Manual Tuning

To manually select a channel, press **CH ▲** or **CH ▼**. Communication channels are located on channel 01-28 and 60-88.

## Mem (Entering channel numbers into Memory Scan)

You can enter channels into Memory Scan for instant scanning at any time. When a channel is selected for Memory Scan, **MEM** appears on the LCD display.

To enter a channel into Memory Scan, select the channel you want to store by using **CH ▲** or **CH ▼**, and then press **MEM**. The channel is stored in Memory Scan and **MEM** appears on the LCD display.

To cancel the channel in Memory, press **MEM**. The MEM icon disappears.

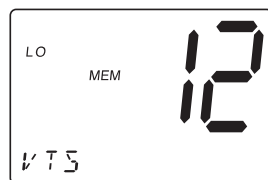

## Triple Watch Scan

To turn Triple Watch Scan On, press and hold **STEP/SCAN** for 2 seconds. While the current channel is scanned, Channel 16 and Channel 9 are also scanned every 2 seconds. Then **TRI** appears.

## Normal Scan

Normal Scan is performed only when the memory CH is registered.

To turn Normal Scan On, press and hold **16/9/TRI** for 2 seconds in **Triple Watch Scan** mode. Although Memory CH is scanned, Channel 16 and Channel 9 are not.

## Transmitting

**Note:** Channel 70 is DSC only. All the available marine channel are located on page 32.

## Setting TX Output

**Caution:** It is important to remember to use the LO position in port or for short range communications.

1. When you turn the radio On for the first time, the unit is automatically set to transmit at 25 watts (**HI**).

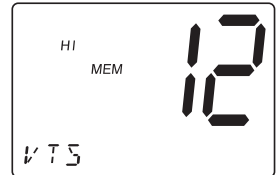

2. Press **HI/LO** to change the transmitter output to 1 watt (**LO**).

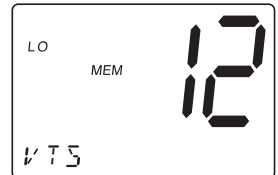

3. Press **HI/LO** again to change back to 25 watts (**HI**).

**Note:** Each time the **HI/LO** is pressed a short tone sounds. When the channel is set as LO power channel, you can transmit at 25 watts (**HI**) by pressing and holding **HI/LO** during the call (except for CH 75 and CH 76).

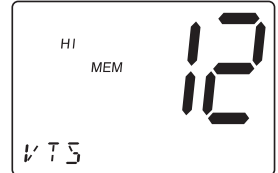

## Distress

**Note:** You must set the user MMSI in order to send a Distress call. Please see page 28 to set the MMSI.

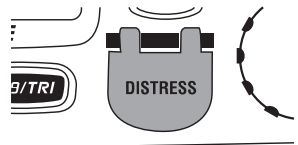

This feature will allow you to transmit a Distress call.

1. In order to transmit a Distress call, press and hold **DISTRESS** for 5 seconds then press **SELECT**.



2. The Distress call is transmitted and it waits for about 210 - 270 seconds. This is continued internally. After the Distress call has been sent, the Distress alert will sound every other second, and it also “shadow-watches” for a transmission between CH16 and CH70 until an acknowledgment signal is received from the Coast Guard shore station.

To cancel the Distress call, press **16/9/TRI**.

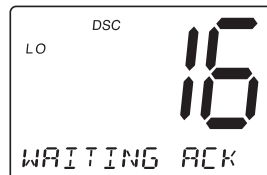

3. When the radio receives a Distress call, the following screen appears. If an acknowledgment is not received, the Distress call is repeated until an acknowledgment is received from the Coast Guard shore station.



**Note:** If the radio receives a Distress call, it will be displayed on the LCD display. An emergency alert will sound. The name will be displayed if it is the name registered in the directory. Otherwise, sender's MMSI is displayed. Latitude, longitude, and time information will also be displayed if the GPS module is carried in the vessel that transmitted a DSC Distress call.

## Switching the Inland waterway Mode/Seagoing Mode

You can switch between Inland waterway mode and Seagoing mode. Press and hold **PA/MENU** to switch between the two.

When the radio in the Inland waterway mode;

- DISTRESS/DSC cannot be transmitted nor received.
- Only ATIS can be transmitted. **WX** blinks.

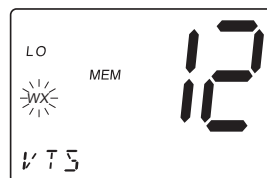

When the radio in the Seagoing mode;

Transmission and reception of DISTRESS/DSC, and transmission of ATIS can be available.

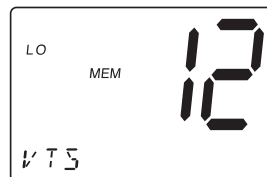

---

# Menu Operation

---

## 1. DIGITAL SELECTIVE CALLING (DSC)

Digital Selective Calling is a process of establishing a radio call, it has been chosen by the International Maritime Organization (IMO) as an international standard for establishing VHF, MF and HF radio calls. Digital Selective Calling has also been selected as part of the Global Maritime Distress and Safety System (GMDSS).

This service will let you instantly send a Distress call with GPS position (when optional GPS receiver is connected to the **MC-8000 DSC**) to the US Coast Guard and other vessels within range of the transmission. DSC will also let you initiate or receive distress, urgency, safety, position information and routine calls to or from another vessel outfitted with a DSC transceiver.

See the directory section **2-D** (p. 23) for instructions on how to setup the directory of names.

- Note:**
- Position **SEND** and **ALARM CLOCK** will not be displayed if GPS is not connected.
  - Refer to page 8 for the flow chart of Menu Operation.

1. Press **MENU** to enter Menu Operation.
2. Press **SELECT** to enter **DSC CALL**.

**DSC CALL** has 7 options as follows.

To exit, select **EXIT**.

### 1-A. INDIVIDUAL

1. Press **SELECT** at **DSC CALL**.

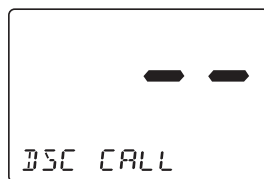
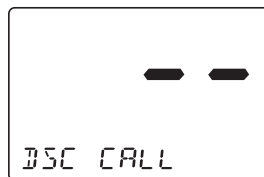

2. **INDIVIDUAL** appears.  
Press **SELECT**.

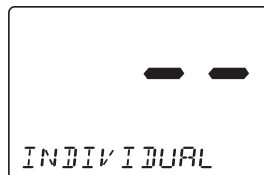

3. Select the individual you want to contact using **CH ▲** or **CH ▼**. Press **SELECT** to transmit the individual DSC signal.

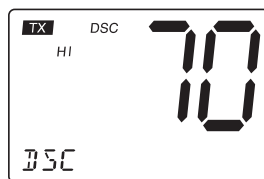

4. **WAITING** appears followed by the individual you have selected, and the radio use 70 CH while transmitting.

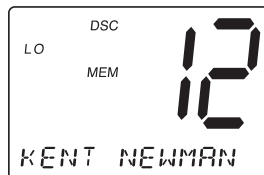

5. When you receive the individual acknowledgment successfully, **WAITING** will change to **COMPLETED**. Both radios tune to the selected channel. You are now ready to transmit on that channel.

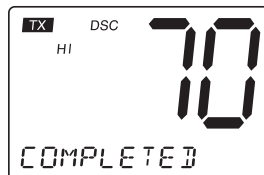

**Note:** *If there is not any data registered in the directory you cannot proceed to the 2nd step. See the **SETUP** section for **Directory** setup instructions page 23. Select an open (unused) working channel first, then make the call. After the acknowledgment, both radios tune to the previously selected channel.*

### 1-B. GROUP

1. Press **SELECT** at **DSC CALL** (To enter **DSC CALL**, see page 15). **INDIVIDUAL** appears.

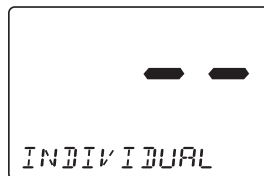

2. Press **CH ▼** once to select **GROUP**.



3. Press **SELECT**. The MMSI code appears, and you can now call the group members. Press **SELECT** to call. When you finish calling, the radio returns to the channel display screen.

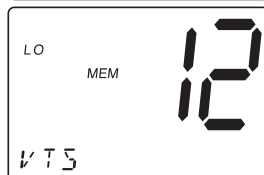
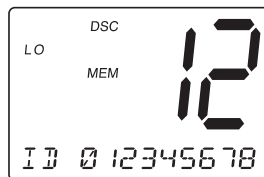

### 1-C. ALL SHIPS

1. Press **SELECT** at **DSC CALL** (To enter **DSC CALL**, see page 15). **INDIVIDUAL** appears.

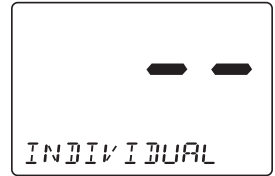

2. Press **CH ▼** twice to select **ALL SHIPS**.

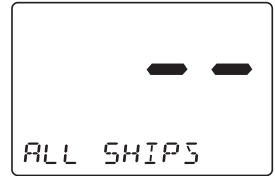

3. Press **SELECT**. **URGENCY** appears.

4. Select the category of your call using **CH ▲** or **CH ▼** (**URGENCY, SAFETY, EXIT**).

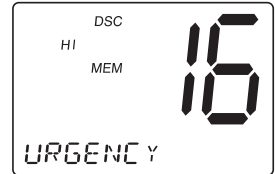

5. Press **SELECT** to transmit the **ALL SHIPS DSC** signal.

When sending either an **URGENCY** or **SAFETY** message, all radios will automatically move to channel 70 until all of the data is received.



6. After selecting **URGENCY** or **SAFETY**, **ALL SHIPS** call is transmitted, the radio will switch to Channel 16. You should wait a few minutes before transmitting the **ALL SHIPS** call information.



### 1-D. POSITION REQUEST

This radio has the ability to request the position of an individual vessel that is registered in the **DIRECTORY**.

1. Press **SELECT** at **DSC CALL** (To enter **DSC CALL**, see page 15). **INDIVIDUAL** appears.

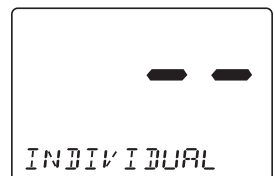

2. Display **POS REQUEST** using **CH ▲** or **CH ▼**.

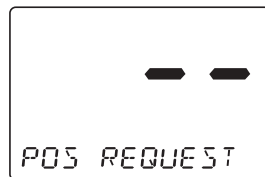

3. Press **SELECT**. The individual directory appears.

4. Select the name to request the individual's position using **CH ▲** or **CH ▼**.

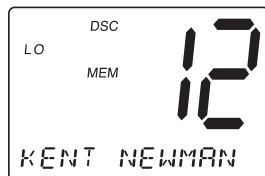

5. Press **SELECT** to transmit the position request call. **POS WAITING** appears followed by the individual, and the radio use 70 CH while transmitting.

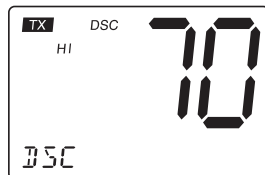

6. When the called vessel sends the position information, time and position appears followed by the individual. You can see the time and the position.



**Note:** The requested radio must have the ability to transmit the position information (such as having a **MC-8000 DSC** radio).

## 1-E. POSITION SEND

This radio has the ability to send the position of your vessel to another vessel using a VHF marine radio equipped with DSC.

**Note:** Position send is only available when it is connected to the GPS.

1. Press **SELECT** at **DSC CALL** (To enter **DSC CALL**, see page 15). **INDIVIDUAL** appears.

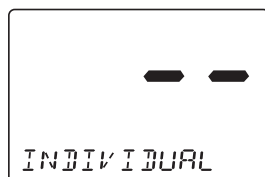

2. Display **POS SEND** using **CH ▲** or **CH ▼**.

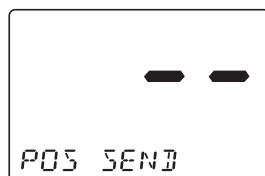

3. Press **SELECT**. The individual directory appears.

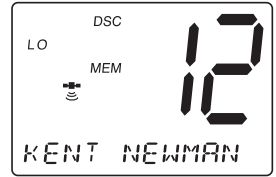

4. Press **SELECT** to send your position information.

5. The following screen appears.

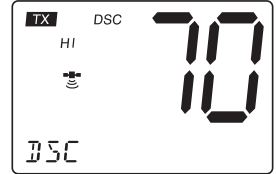

## 1-F. STANDBY

The DSC STANDBY function allows the **MC-8000 DSC** to answer DSC calls with the UNATTENDED message and record the calls for response at another time. When you set the radio to DSC STANDBY mode, voice traffic may still be active on any chosen channel.

1. Press **SELECT** at **DSC CALL** (To enter **DSC CALL**, see page 15). **INDIVIDUAL** appears.

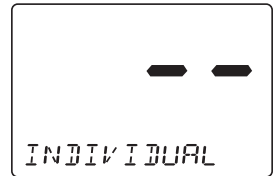

2. Display **STANDBY** using **CH ▲** or **CH ▼**. Then press **SELECT**.



3. When an individual DSC call is received, the radio will respond with the **UNATTENDED** message when an operator cannot answer the call. The DSC call will be recorded into the radio's Call Waiting directory.

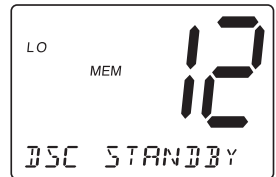

**Note:** If you press a key on the radio or the PTT, this feature will be canceled.

## 1-G. CALL WAIT

The DSC Call Waiting directory records 10 received distress calls, and records 20 individual calls that are received and not answered within 5 minutes or while the radio is set to DSC Standby. Calls will be recorded while you are busy with other communications as long as the transmitter is not keyed at the time of the call. If the call is answered within 5 minutes the call will not be recorded. When a call is recorded, a message appears.

1. Press **SELECT** at **DSC CALL** (To enter **DSC CALL**, see page 15). **INDIVIDUAL** appears.

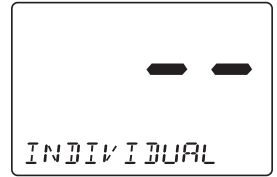

2. Display **CALL WAIT** using **CH ▲** or **CH ▼**.

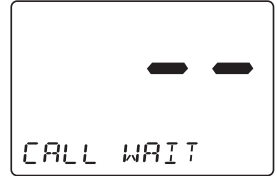

3. Press **SELECT**. The **CALL WAIT** directory appears.

4. Select the options you want to view using **CH ▲** or **CH ▼**.



**Note:** If a call has not been logged, the radio will beep and you will not be able to proceed to the next step.

5. Press **SELECT**.
6. If a **DISTRESS** call is received in Call Wait, the following display appears.

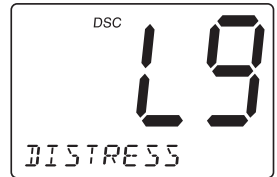

If an **INDIVIDUAL** call is received in Call Wait, the following display appears. At this point, you can call back any of the radios in the log.

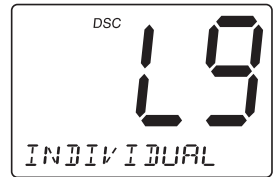

7. Press **SELECT**. Received data appears.



8. Using **CH ▲** or **CH ▼** allows you to look through all of the data. If you press **SELECT**, the radio starts transmitting.

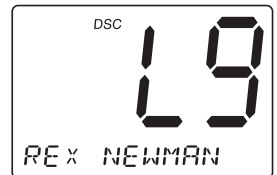

## 2. SETUP

1. Press **MENU** to enter Menu Operation.
2. Press **CH ▼** once to display **SETUP**, and press **SELECT**.



**SETUP** has some options as follows. To exit, select **EXIT**.

### 2-A. ALARM CLOCK

This feature is only available when the GPS is connected to the NMEA0183 Accessory Wires. If it is connected to the GPS, the alarms are set based on the satellite. You need to set the time previously to setting the alarm.

#### 2-A-1. ALARM SET

This feature allows you to set the alarm.

1. Press **SELECT** at **SETUP**. **ALARM CLOCK** appears.
2. Press **SELECT**.
3. Press **CH ▲** or **CH ▼** to select **On**. Then, press and hold **SELECT**.
4. Select the hour using **CH ▲** or **CH ▼**, then press **SELECT**.
5. Select the minute using **CH ▲** or **CH ▼**, then press **SELECT**.
6. Select **AM** or **PM** using **CH ▲** or **CH ▼**, then press **SELECT**.
7. A confirmation screen appears.

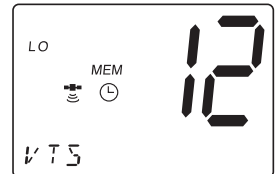

#### 2-A-2. ALARM ON

This feature allows you to turn the alarm ON.

1. Press **SELECT** at **SETUP** (To enter **SETUP**, see above).
2. **ALARM CLOCK** appears. Then, press **SELECT**.
3. Press **SELECT** again.



4. Select **On**. Using **CH ▲** or **CH ▼**, and press **SELECT**. The radio returns to the channel display screen and the icon ☹ appears.



5. When the radio reaches the set time the alarm sounds and the icon ☹ blinks.

**Note:** The alarm sounds when the set time is reached, you can turn the alarm Off by pressing any key. Alarm mode will turn Off automatically once the alarm sounds.

### 2-A-3. ALARM OFF

This feature allows you to turn the alarm OFF.

1. Press **SELECT** at **SETUP** (To enter **SETUP**, see page 21).



2. **ALARM CLOCK** appears.



3. Press **SELECT**.

4. Select **OF** using **CH ▲** or **CH ▼**, then press **SELECT**.



5. Press **SELECT**. The radio returns to the channel display screen and the icon ☹ disappears.

### 2-B. LOCAL TIME ADJUST

This feature allows you to fine tune the Local Time for any location in Europe. The feature enables you to adjust the Local time by  $\pm 1$  hour.

#### To set LOCAL TIME ADJUST

1. Press **SELECT** at **SETUP** (To enter **SETUP**, see page 21).



2. Display **LOCAL TIME ADJUST** using **CH ▲** or **CH ▼**.

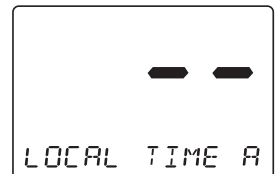

3. Press **SELECT**. The registering screen appears. You can now adjust the time for your local area using **CH ▲** or **CH ▼**.

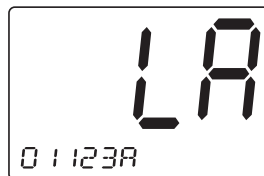

4. The time will be entered when you press **SELECT**. The display returns to **LOCAL TIME ADJUST** screen.

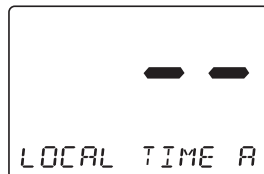

## 2-C. DAYLIGHT SAVINGS On/Off

This feature enables you to select the automatic Daylight Savings clock setting.

### To set DAYLIGHT SAVINGS On/Off

1. Press **SELECT** at **SETUP** (To enter **SETUP**, see page 21).



2. Display **DAYLITE SAVE** using **CH ▲** or **CH ▼**.



3. Press **SELECT**. Then press **CH ▲** to set DAYLIGHT SAVINGS **On** or **CH ▼** to OFF (the default setting is **OF**).



4. Press **SELECT**. The display returns to **DAYLITE SAVE** screen.



## 2-D. DIRECTORY

This function will allow you to send an individual call, etc. The Directory function memorizes the name and MMSI number of 20 other vessels. The following screen will allow you to setup an alphanumeric identity as well as the corresponding MMSI number.

1. Press **SELECT** at **SETUP** (To enter **SETUP**, see page 21).



2. Display **DIRECTORY** using **CH ▲** or **CH ▼**.



3. Press **SELECT**. The **DIRECTORY** menu appears. Use **CH ▲** or **CH ▼** to select the menu.

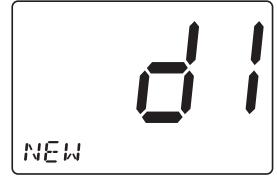

### 2-D-1. NEW

This function will allow you to enter new information into the directory.

1. Press **SELECT** at **NEW**. The registering screen appears.



2. You can now enter the person's name. Using the number key pad on the mic, choose the alphabet. The character will be entered when **SELECT** or the different number key is pressed, and the blinking digit moves to the right.



3. After you enter the person's name, you can enter their MMSI number. Using the number key pad on the mic, enter their MMSI number. The number will be entered when **SELECT** or the different number key is pressed, and the blinking digit will move to the right.

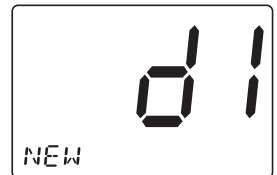

4. When you finish entering the last digit, the radio returns to **NEW** screen.

### 2-D-2. EDIT

If you want to edit the **DIRECTORY**

1. Press **SELECT** at the individual you want to edit.



2. **EDIT** appears, then press **SELECT**.



3. You can now edit the person's name using the number key pad on the mic choose the alphabet.

- After you edit the person's name, you can edit the MMSI. The number will be entered when **SELECT** or the different number key is pressed, and the blinking digit moves to the right.
- After the directory data is edited, the individual appears.



### 2-D-3. DELETE

#### If you want to delete the directory

- Press **SELECT** at the individual you want to delete.
- Press **CH ▼** once. **DELETE** appears, then press **SELECT**.
- The radio displays the next individual. If no more code remains, **EXIT** appears.

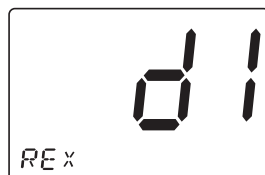
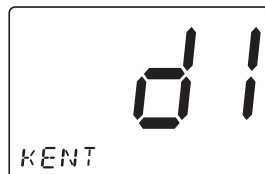

### 2-E. AUTO CHANNEL SWITCH

This feature is to allow you to disable the automatic channel change that happens when receiving a DSC call. This feature is useful when engaged in bridge – to – bridge or other safety related calls. When you have completed these calls, all of the incoming DSC calls received are available in the call log.

- Press **SELECT** at **SETUP** (To enter **SETUP**, see page 21).



- Display **AUTO CH SW** using **CH ▼** or **CH ▲**.

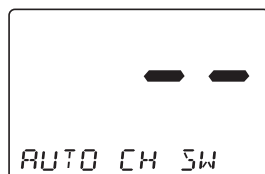

3. Press **SELECT** to enter the setting mode.

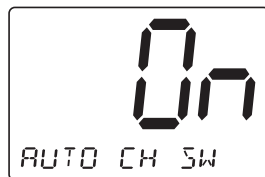

4. If you want to change this mode to **off**, press **CH ▼** once. (Default is set as **On**).

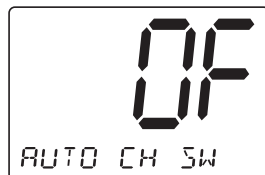

5. Press **SELECT**. The radio returns to the **AUTO CH SW** screen.

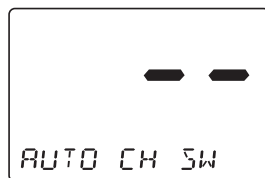

## 2-F. POSITION REPLY

When the calling radio has requested the position information of your radio, you can decide to transmit an acknowledgment automatically or on a call by call basis.

1. Press **SELECT** at **SETUP** (To enter **SETUP**, see page 21).

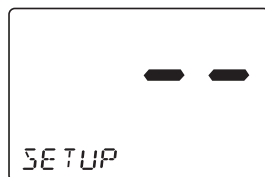

2. Display **POS REPLY** using **CH ▲** or **CH ▼**.



3. Press **SELECT** to enter the setting mode.

4. Press **CH ▲** or **CH ▼** to make your selection.



### **Example: On**

When the radio receives a position request, the following screen appears.



**Example: OF**

When the radio receives a position request, the following screen appears. You can select whether reply the request or not. If you wants to reply press **SELECT**.

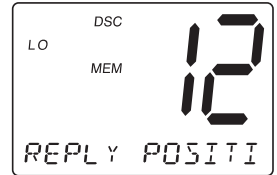

5. Press **SELECT**. The radio returns to the **POS REPLY** screen.



**2-G. CH TAG**

This feature allows you to name each marine channel.

1. Press **SELECT** at **SETUP** (To enter **SETUP**, see page 21).



2. Display **CH TAG** using **CH ▲** or **CH ▼**.

3. Press **SELECT**. The channels and its names appear.

4. Press **CH ▲** or **CH ▼** repeatedly to select the channel that you would like to **EDIT**.

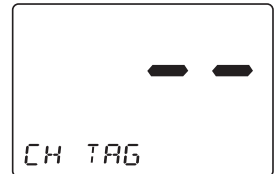

**Note:** The **MC-8000 DSC** radio comes pre-programmed with default channel names.

**2-G-1. EDIT**

If you want to edit the channel name

1. Press **SELECT** at the individual channel you want to edit.



2. You can edit the name using the number key pad on the mic to select the alphabet, numeric, or symbols. The character will be entered when **SELECT** or the different number key is pressed, and the blinking digit moves to the right.



3. Press and hold **SELECT** when you enter the last digit.



## 2-H. GROUP MMSI

1. Press **SELECT** at **SETUP** (To enter **SETUP**, see page 21).

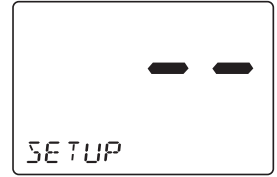

2. Display **GROUP MMSI** using **CH ▲** or **CH ▼**.



3. Press **SELECT**. The group MMSI ID screen appears.

4. You can now enter the GROUP MMSI code. Use the number key pad on the mic to display the number. The number will be entered when **SELECT** or the different number key is pressed, and the blinking digit moves to the right.

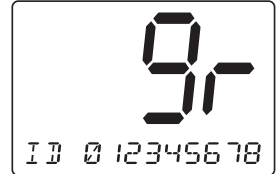

5. After the final digit is entered, a confirmation screen appears. Press **SELECT** and the radio returns to the following screen.

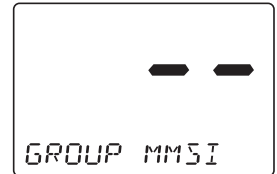

## 2-I. USER MMSI

You will need to obtain a nine digit MMSI number and program it into the **MC-8000 DSC**. To obtain an MMSI number, contact your authorized GPE dealer. This portion of the **SETUP** menu will allow you to program an MMSI, (Maritime Mobile Service Identity) for sending and receiving DSC calls.

### To set **USER MMSI** code

1. Press **SELECT** knob at **SETUP**.



2. Press **CH ▼** eight times to select **USER MMSI**.

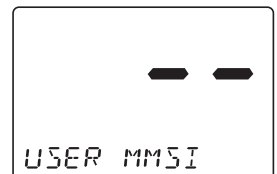

3. Press **SELECT**. The user MMSI ID screen appears.

- You can now enter the USER MMSI code. Press **CH ▼** to increase the number, **CH ▲** to decrease. The number will be entered when **SELECT** is pressed, and the blinking moves to the right.

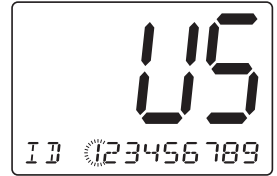

- After the final digit is entered, press and hold **SELECT**. The radio returns to **USER MMSI** screen.

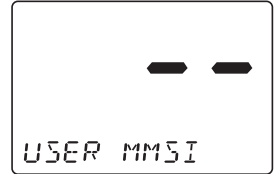

**Note:** You can only program your radio once with an MMSI number. After that, send your radio to GPE for factory service.

## 2-J. ATIS ID

ATIS is the automatic transmitter identification system. The ATIS ID is composed by number of 10 digits, and it is already registered to your radio. The first digit is pre-selected to "9", but it doesn't appear on the display. From 2<sup>nd</sup> to last digits are displayed.

### To confirm the ATIS ID

- Press **SELECT** knob at **SETUP**.



- Press **CH ▼** nine times to select ATIS ID.

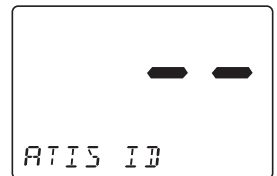

- Press **SELECT**. The ATIS ID number appears



### 3. SYSTEM

1. Press **MENU** to enter Menu Operation.
2. Press **CH ▼** twice to display **SYSTEM**, and press **SELECT**. **SYSTEM** has 3 options as follows. To exit, select **EXIT**.

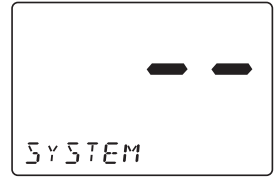

#### 3-A. CONTRAST

1. Press **SELECT** at **SYSTEM**. **CONTRAST** appears.
2. Press **SELECT** to enter the setting mode. (Default is set at 7).
3. Press **CH ▲** or **CH ▼** to increase or decrease the contrast level.
4. When you find the most favourable brightness, press **SELECT**. The radio returns to the **CONTRAST** screen. If you want to exit the setting screen without changing the contrast, press **MENU**.

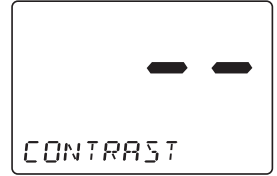

**Note:** There are 8 contrast levels (0 - 7).

#### 3-B. LAMP ADJUST

1. Press **SELECT** at **SYSTEM** (To enter **SYSTEM**, see above).
2. Press **CH ▼** once to select **LAMP ADJUST**.
3. Press **SELECT** to enter the setting mode. (Default is set at 3).
4. Press **CH ▲** or **CH ▼** to select the backlight brightness level.

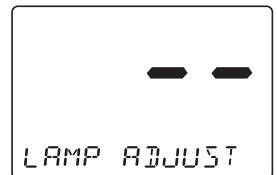
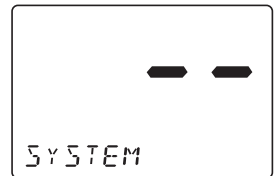

5. When you find the most favourable brightness, press the **SELECT**. The radio returns to the **LAMP ADJUST** screen.

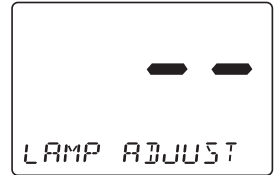

**Note:** The backlight settings are off, Level 1 Dim, Level 2 medium, and Level 3 bright.

### 3-C. KEY BEEP

1. Press **SELECT** at **SYSTEM**. (To enter **SYSTEM**, see page 30).

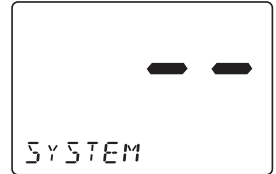

2. Press **CH ▼** twice to select **KEY BEEP**.



3. Press **SELECT** to enter the setting mode.  
4. Press **CH ▲** or **CH ▼** to select **ON (On)** or **OFF (OF)**.



5. Press **SELECT**. The radio returns to the **KEY BEEP** screen.



---

## NMEA Technical Setup

---

### MC-8000 DSC NMEA0183 GPS Input Connection

An external GPS can be attached to the **MC-8000 DSC** via NMEA 0183 serial data output which is used to supply position, date and time data, speed and direction.

# VHF FM Marine Radio Telephone Channel and Functions

## (International Channels)

CHANNEL DESIG	FREQUENCY (MHz)		TYPE OF TRAFFIC	SHIP TO SHIP	SHIP TO SHORE
	TRANSMIT	RECEIVE			
01	156.050	160.650	VTS,Duplex	Yes	Yes
02	156.100	160.700	Port Ops,Duplex	Yes	Yes
03	156.150	160.750	Port Ops,Duplex	Yes	Yes
04	156.200	160.800	Port Ops,Duplex	Yes	Yes
05	156.250	160.850	VTS,Duplex	Yes	Yes
06	156.300	156.300	Safety	Yes	No
07	156.350	160.950	Com'l,Duplex	Yes	Yes
08	156.400	156.400	Com'l	Yes	No
09	156.450	156.450	Com'l & Non Com'l	Yes	Yes
10	156.500	156.500	Com'l	Yes	Yes
11	156.550	156.550	Com'l	Yes	Yes
12	156.600	156.600	Port Ops	Yes	Yes
13	156.650	156.650	Navigational	Yes	Yes
14	156.700	156.700	Port Ops	Yes	Yes
15	156.750	156.750	Environmental	Yes	Yes
16	156.800	156.800	Safety Calling	Yes	Yes
17	156.850	156.850	State Control	Yes	Yes
18	156.900	161.500	Com'l,Duplex	Yes	Yes
19	156.950	161.550	Com'l,Duplex	Yes	Yes
20	157.000	161.600	Port Ops,Duplex	Yes	Yes
21	157.050	161.650	Coast Guard,Duplex	Yes	Yes
22	157.100	161.700	Coast Guard,Duplex	Yes	Yes
23	157.150	161.750	Coast Guard,Duplex	Yes	Yes
24	157.200	161.800	Public Corresp,Duplex	No	Yes
25	157.250	161.850	Public Corresp,Duplex	No	Yes
26	157.300	161.900	Public Corresp,Duplex	No	Yes
27	157.350	161.950	Public Corresp,Duplex	No	Yes
28	157.400	162.000	Public Corresp,Duplex	No	Yes
60	156.025	160.625	Duplex		
61	156.075	160.675	Duplex		
62	156.125	160.725	Duplex		
63	156.175	160.775	Duplex		
64	156.225	160.825	Duplex		
65	156.275	160.875	Port Ops,Duplex	Yes	
66	156.325	160.925	Port Ops,Duplex	Yes	Yes
67	156.375	156.375	Com'l	Yes	No
68	156.425	156.425	Non Com'l	Yes	Yes
69	156.475	156.475	Non Com'l	Yes	Yes
70	DSC only	156.525	DSC		
71	156.575	156.575	Non Com'l	Yes	Yes
72	156.625	156.625	Non Com'l	Yes	No
73	156.675	156.675	Port Ops	Yes	Yes
74	156.725	156.725	Port Ops	Yes	Yes
75	156.775	156.775			
76	156.825	156.825			
77	156.875	156.875	Port Ops	Yes	No
78	156.925	161.525	Non Com'l,Duplex	Yes	Yes
79	156.975	161.575	Com'l,Duplex	Yes	Yes
80	157.025	161.625	Com'l,Duplex	Yes	Yes
81	157.075	161.675	Coast Guard,Duplex	Yes	Yes
82	157.125	161.725	US Govt Only,Duplex	Yes	Yes
83	157.175	161.775	Coast Guard,Duplex	Yes	Yes
84	157.225	161.825	Public Corresp,Duplex	No	Yes
85	157.275	161.875	Public Corresp,Duplex	No	Yes
86	157.325	161.925	Public Corresp,Duplex	No	Yes
87	157.375	157.375	Public Corresp,Simplex	No	Yes
88	157.425	157.425	Com'l,Simplex	Yes	No

---

# Specification

---

## General

Controls	: On-Off/Volume, Squelch
Status Indicators	: TX (Transmit), TRI (Triple Watch), HI (High), LO (Low), I, MEM, DSC, (L) (Alarm),  (GPS), WX (Navigation Mode) and Channel Display
Channel Display	: LCD with Orange backlight
Buttons	: 16/9/TRI, DISTRESS, PA, MEM, SELECT, STEP/SCAN, MENU, HI/LO
Connectors	: Antenna, Remote, ACC, and DC power
Size	: H63 mm x W160 mm x L168 mm (W/O Heat Sink) H3.07 inches x W7.24 inches x L6.61 inches
Weight	: 1.0 kg / 2.65 lbs / 42.3 oz
Supply Voltage	: 13.8 V DC negative ground
Standard Accessories	: Mounting bracket and hardware, DC power cord, microphone hanger, spare fuse, ACC Cable
Antenna Impedance	: 50 $\Omega$ nominal
Microphone	: Rugged 2 k $\Omega$ condenser mic element with coiled cord
Speaker	: 1.82 inch, Mylar Cone 8 $\Omega$
Operating Temperature Range	: -15 °C to + 55 °C (+4 °F to +131 °F)
Shock and Vibration	: Meets or exceeds EIA standards, RS152B and RS204C

## Transmitter

Power Output	: 1 watt or 25 watt (switch selectable)
Power Requirement	: Not rated on LO, 25 watts output: 5.6A@13.8V DC
Modulation	: FM $\pm$ 5 kHz deviation
Hum and Noise Signal-to-Noise	: 45 dB@1 kHz with 3 kHz deviation with 1000 Hz modulating frequency (nominal)
Audio Distortion	: Less than 8% with 3 kHz deviation with 1000 Hz modulating frequency
Spurious Suppression	: -70 dBc @ Hi, -70 dBc @ Lo
Output Power Stabilization	: Built-in automatic level control (ALC)
Frequency Range	: 156 to 158 MHz
Frequency Stability	: $\pm$ 10 ppm @ -15°C to + 55°C

## Receiver

Frequency Range	: 156 to 163 MHz
Sensitivity	: 0.25 $\mu$ V for 12 dB SINAD
Circuit	: Dual Conversion Super Heterodyne PLL
Squelch Sensitivity	: 0.8 $\mu$ V Threshold
Spurious Response	: 70 dB
Adjacent Channel Selectivity	: 75 dB @ $\pm$ 25 kHz
Audio Output Power	: 2.8 watts (10% Distortion)
Power Requirement	: 200 mA @ 13.8V DC squelched, 0.7A @ 13.8V DC at maximum audio output
IF Frequencies	: 1st 21.4 MHz, 2nd -455 kHz

---

## Troubleshooting

---

If the **MC-8000 DSC** does not perform to your expectations, try the suggestions listed below. If you cannot get satisfactory results, call the GPE Technical Support

<b>SYMPTOM</b>	<b>CAUSE</b>	<b>REMEDY</b>
Won't power On.	No or low voltage.	Check for proper voltage getting to the set.
When the PTT is pressed - Tx icon comes on and another radio can hear a "click" but no audio is heard.	Bad mic element.	Send in for repair.
While scanning, the radio stops on a particular channel all of the time.	A source of noise is nearby.	Eliminate the source of the noise or delete the channel from the scanner.
There is noise on the receiver that the squelch will not eliminate.	An external noise is being generated by some device.	Either turn off the offending device or contact that Mfg.

---

## Warranty

---

This transceiver has a 3 years warranty for materials and workmanship in its country of purchase against any manufacturing defect recognized by our technical department. It is recommended to read carefully following conditions and to respect them in order not to loose it.

- Any repair under warranty will be free of charge and the transport costs for sending back will be on charge of our company.
- A proof of purchase must compulsorily be added to the transceiver in need of repair.
- Don't install your transceiver without having read this instructions manual.
- Our technical department won't send nor exchange any spare parts as part of warranty.

### **Are not covered**

- Immersion higher than : 30 minutes, 1 meter (IPX7)
- Damages caused by accident , shock , inadequate packing or the use of accessories that are not in conformity.
- Interventions that modified the conformity features, repairs or modifications done by third parties which are not agreed by our company.
- Any opening of the housing cancels the warranty.

# CERTIFICATE OF CONFORMITY

We, GROUPE PRESIDENT ELECTRONICS, Route de Sète,  
BP 100 – 34540 Balaruc – FRANCE,

Declare, on our own responsibility that the Marine VHF radio-  
communication transceiver,

Brand : **PRESIDENT**  
Model : **MC-8000 DSC**  
Manufactured in P.R.C.

is in conformity with the essential requirements of the Directive  
1999/5/CE (Article 3) adapted to the national law, as well as  
with the following European Standards:

**EN 301 025 / EN 60945 / EN 60215**

Balaruc, the 01/12/2004

A handwritten signature in black ink, appearing to read 'J. G. Muller', written over a horizontal line.

Jean-Gilbert MULLER  
*General Manager*

Groupe  
**PRESIDENT**  
ELECTRONICS

Siège Social / Head Office France – Route de Sète  
BP 100 – 34540 BALARUC

Site internet : <http://www.president-electronics.com>

E-mail : [groupe@president-electronics.com](mailto:groupe@president-electronics.com)



CE 0336 !

0657/02-05  
UTZZ01604ZZ