

DC to AC Power inverter manual

HT-P-252A1

2500W

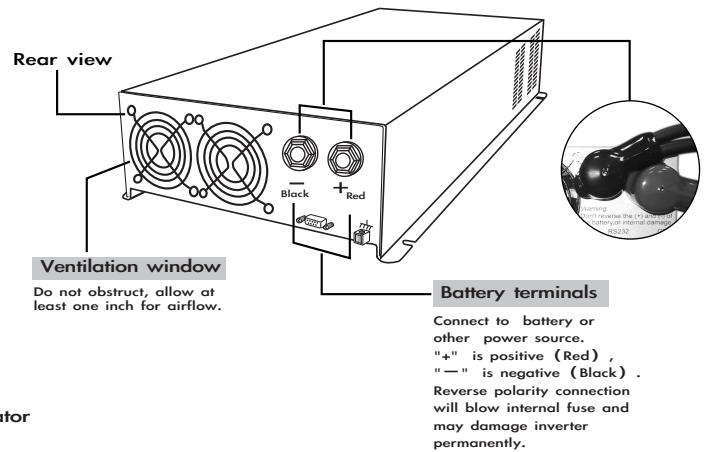
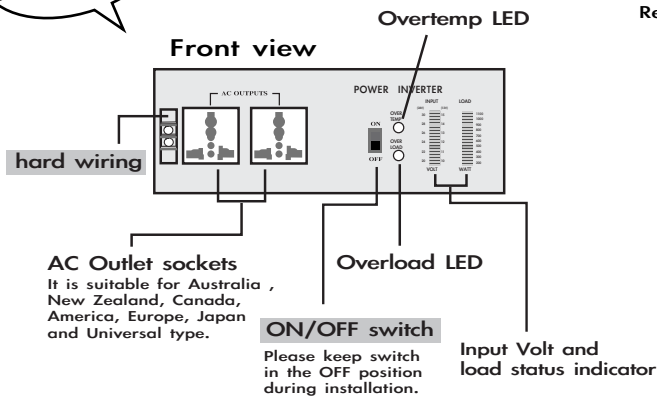

SPECIFICATIONS

Model No.	HT-P-2500-12	HT-P-2500-24	HT-P-2500-48
Continuous Output Power	2500W		
Max Output Power	5000W		
DC Input Voltage	DC12V	DC24V	DC48V
AC Output Voltage	100VAC / 110VAC 120VAC / 220VAC 230VAC / 240VAC		
Frequency	50Hz / 55Hz/60Hz \pm 3 Hz		
Regulation	\pm 5%		
No Load current Draw	<0.7A	<0.4A	<0.2A
Efficiency (Optimum Efficiency)	>85%		
Output Waveform	Modified Sine Wave		
Input Low Voltage Alarm	YES		
Input Low Voltage Protection	YES		
Input High Voltage Protection	YES		
Overload Protection	YES		
Temperature Protection	(55°C \pm 5°C)		
Output Short Circuit Protection	YES		
Overload Instruction	YES		
Temperature Instruction	YES		
Battery Voltage Indicator	YES		
Output Watt Indicator	YES		
Dimensions (L x W x H / mm)	550 x 274 x 105		
Net Weight (by Kg/s)	7.8Kgs		
Gross Weight (by Kg/s) ..with cable	9.5		

To get the most out of the power inverter, it must be installed and used properly. Please read the instructions in this manual before installing and using this model.

Name and Main function

1. Front view

- ON/OFF switch:
Set OFF position during installation.
- Over heat indicator:

Lights when inverter protects itself against overheating, inverter shut down while indicator is on. Please turn on the inverter again when it cools down.

c. Overload indicator:

Lights when inverter shut down due to overloading. Turn inverter OFF, remove cause of overload and turn inverter ON to reset.

d. Bar graph meters:

Display battery voltage and watt. Watt should be in the green zone for continuous operation. The inverter will operate for several minutes when the watt in the red zone.

e. AC outlet:

Outlet sockets available:

- Australia/NZ
- North America
- Europe (European Schuko, German, UK)
- Universal
- Japan

2. Rear view:

a. Earth:

Please use #8 AWG wire to earthed or connect to vehicle chassis.

WARNING!! Operation of the inverter without a proper ground connection may result in an electrical safety hazard.

b. Ventilation window:

Do not obstruct, allow at least one inch for ventilate.

c. Battery terminals:

Connect to 12V/24V battery or others 12V/24V power source. The "+" is positive, "-" is negative. The terminals have to connect corrected. Reverse polarity connection will blow internal fuse and may damage inverter permanently.

Quick hookup and testing

If you would like to quick hookup the power inverter and check its performance before going ahead with your installation, please follow these guidelines:

- Unpack and inspect the power inverter, check to see that the power switch in the OFF position.
- Connect the cables to the power input terminals on the rear panel of power inverter. The red terminal is positive (+) and black terminal is negative (-). Connect the cables into the terminals and tighten the wing nut to clamp the wires securely.

3. Connect the cable from the negative terminal of the inverter to the negative terminal of the power source. Make a secure connection.

CAUTION!! Loosely tightened connectors result in excessive drop and may cause overheated wires and melted insulation.

4. Before proceed further, carefully check that cable you have just connected connects from the negative terminal of inverter to the negative output terminal of the power source.

CAUTION!! Reverse polarity connection will blow fuse in inverter. **Damage caused by reverse polarity connection is not covered by our warranty.**

5. Connect the cable from the positive terminal of inverter to the positive terminal of the power source. Make secure connection.

WARNING!! You may observe a spark when you make this connection since current may flow to charge capacitors in the power inverter. Do not make this connection in the presence of flammable materials, explosions or fire may result.

6. Set the power switch to the ON position. Check the meters and indicators on the front panel of the inverter. The voltage bar graph should indicate 11 to 14 volts (22 to 28V when 24V version is used) depending on the voltage of the power source.

If does not, check your power source and the connections to inverter. The other indicators should be off.

7. Set power inverter switch to the OFF position, the indicator lights may blink and the internal alarm may sound momentarily. This is normal.

8. Set power inverter switch to the ON position, then the inverter should supply power to the load. After that, turn the test load on.

Installation

1. Where to install

The power inverter should be installed in a location that meets the following requirements:

- Dry – Do not allow water to drip or splash on the inverter.
- Cool – Ambient air temperature should be between 0°C and 40°C, the cool, the better.
- Ventilated – Allow at least one inch of clearance around the inverter for airflow. Ensure the ventilation openings on the rear and bottom of the unit are not obstructed.
- Safe – Do not install the inverter in the same compartment as batteries or in any compartment capable of storing flammable liquids such as gasoline.

Firstly, thank you for purchase our product.

Please read this manual carefully before installing or using this product.

Introduction

The power inverter series are the member of the most advanced line of mobile AC power systems available. This model is used in a wide range of application including remote homes, RVs, sailboats and powerboats. It will operate most televisions and VTR, personal computers, small appliances and tools such as drills, sanders, grinders, mixers and blenders.

2. Cables

DC to AC inverters requires high amperage/low voltage DC power to low amperage/high voltage AC power. To operate properly connect inverter DC input terminals direct to battery with heaviest wire available see chart below:

Max Watts Out	Approx. Amps	Teq'dWire Gauge
100W	10A	#16
150W	15A	#16
300W	30A	#12
600W	60A	#6 or 2 X #10
1000W	100A	#4
1200W	120A	#4
1500W	150A	#4
1800W	180A	2 X #4
2500W	250A	2 X #4

3. Grounding

The power inverter has a lug on the rear panel "chassis ground". This is to connect the chassis of the power inverter to the ground. The ground terminals in the AC outlets on the front panel of the inverter are also connected to the ground lug. The chassis ground lug must be connected to a grounding point, which will vary depending on where the power inverter is installed. In a vehicle, connect the chassis ground to the chassis of the vehicle. In a boat, connect to the boat's grounding systems. In a fixed location, connect the chassis ground lug to earth.

The neutral (common) conductor of the power inverter AC output circuit is connected to the chassis ground. Therefore, when the chassis is connected to ground, the neutral conductor will also be grounded. This conforms to national electrical code requirements that separately derived AC sources (such as inverters and generators) have their neutral tied to ground in the same way that the neutral conductor from the utility line is tied to ground at AC breaker panel.



Caution!

The negative DC input of the power inverter is connected to the chassis. Do not install the power inverter in a positive ground DC system. A positive ground DC system has the positive terminal of the battery connected to the chassis of the vehicle or to the grounding point.



Warning!

Do not operate the power inverter without connecting it to ground. Electrical shock hazard may result.

Operation

To operate the power inverter, turn it on using the ON/OFF switch on the front panel. The power inverter is now ready to deliver AC power to your loads. If you are operating several loads from the power inverter, turn them on separately after the inverter has been turned on. This will ensure that the power inverter does not have to deliver the starting currents for all the loads at once.

1. Controls and indicators

The ON/OFF switch turns the control circuit in the power inverter on and off. It does not disconnect power from the power inverter.

When the switch is in the OFF position, the power inverter draws no current from battery. When the switch is in the ON position but with no load, the power inverter draws less than 450mA (12V version) or 300 mA (24V version) from battery.

2. Battery voltage indicator

The battery voltage graph indicates the voltage at the input terminals of the power inverter. At low input current, this voltage is very close to the battery voltage. At high input current, this voltage will be lower than the battery voltage because of the voltage drop across the cable and connections. Ideally, the voltage should remain in the green area of the bar graph. If the voltage goes into the red area at top and bottom of the graph, inverter may shutdown.

3. Load percentage indicator

The load watts graph indicates the watts of the appliances you use. If the load goes into the red area at top, inverter may shut down.

4. Overtemp indicator

The overtemp indicator indicates that the power inverter has shut itself down because it is overheated. The power inverter may overheat because it has been operated at power levels above its rating, or because it has been installed in a location which does not allow it to dissipate heat properly.

Please turn on the inverter again when it cools down.

5. Overload indicator

The overload indicator indicates that the power inverter has shut itself down because its output circuit has been short circuited or drastically overloaded.

Turn off the inverter, correct the fault condition or reduce load, then turn on the inverter and try again.

Operating limits

1. Input voltage

The power inverter will operate from input voltage ranging 10V-15V (12V ver.) or 20V - 30V (24V ver.). If the voltage drops below 10.5V (12V ver.) or 21.0V (24V ver.), an audible low battery warning will sound and the voltage indicator will be in the lower red zone.

The power inverter will shut down if the input voltage drops below 10V (12V ver.) or 20V (24V ver.). This protects your battery from being over discharged.

The power inverter will also shut down if the input voltages exceed 15V (12V ver.) or 30V (24V ver.). This protects the inverter against excessive input voltage indicator will be in the upper red zone.

Although the power inverter incorporates protection against over voltage, it may still be damaged if the input voltage is allowed to exceed 20V (12V ver.) or 40V (24V ver.).

※The error of above spec is $\pm 0.5V$

Troubleshooting

1. Common problems

a. Buzz in audio systems:

Some inexpensive stereo systems and "boom boxes" will emit a buzzing noise from their loudspeakers when operated from the power inverter. This is because the power supply in the device does not adequately filter the modified sine wave produced by the power inverter. The only solution is to use a sound system that incorporates a higher quality power supply.

b. Television interference:

Operation of the power inverter can interfere with television reception on some channels. If this situation occurs, the following steps may help to alleviate the problem.

-Make sure that the chassis ground lug on the back of the power inverter is solidly connected to the ground system of your vehicle, boat or home.

-Do not operate high power loads with the power inverter while watching television.

-Make sure that the antenna feeding your television provides an adequate ("snow free") signal and that you are using good quality cable between the antenna and the television.

-Move the television as far away from the power inverter as possible.

-Keep the cables between the battery and the power inverter as short as possible and twist them together with about 2 to 3 twists per foot. This minimizes radiated interference from the cables.

2. Troubleshooting guide

Problem	possible cause	solution
No Output voltage	1. Make sure that inverter cable connects to battery well	1. Re-set the cable
No voltage indicator	2. Internal fuse blown out	2. Change new fuse
Inverter shuts down and overload light shows	Overload	Reduce load
Inverter shuts down and overtemp light shows	Overtemperature	Improve ventilation reduce inverter temperature or let it cool down naturally
Low battery alarm	Battery volt is low	Charge battery

Maintenance

Very little maintenance is required to keep your inverter operating properly. You should clean the exterior of the unit periodically to prevent accumulation of dust and dirt. At the same time, tighten the screws on the DC input terminals.

Warranty

We offer 12 months warranty from the date of purchase and will repair or replace any defective power inverter, this limited warranty is void if the unit is abused, modified, installed improperly, if the housing has been removed, if the serial number is missing, or if the original identification markings have been defaced, altered, or removed. The supplier is not liable for any incidental, consequential or other damages arising from the use, cost of removal, installation, or troubleshooting of the customer's electrical systems.

This is only warranty and the company makes no other warranties, express or implied, including warranties of merchantability and fitness for a particular purpose.

Repair or replacement are your sole remedies and shall not be liable for damages, whether direct, incidental, special or consequential, even though caused by negligence or other fault.